

United Air Specialists, Inc.

a CLARCOR company

## V SERIES



Model VP



Model VB



Model VF

*Clean air. It's what we do.™*

VERSATILE/PORTABLE CARTRIDGE DUST COLLECTORS

# V Series

Your Most  
VERSATILE and  
ECONOMICAL  
Solution  
for CAPTURING  
DUST and DRY  
POLLUTANTS.

## ALL-PURPOSE DUST COLLECTOR

If you're looking for a versatile, cost-effective alternative for eliminating fumes and dust in your factory, look no further than United Air Specialists' V Series. This innovative cartridge dust collection system is specifically designed to capture the smoke, dust and powders that result from a variety of manufacturing operations.



Model VP-1500 (Portable)



With a choice of two compact, low-profile sizes—750 or 1,500 CFM—the V Series truly is the most economical solution for cleaner factory air.

## A WIDE RANGE OF APPLICATIONS

The versatile and compact V Series is ideal for applications including:

- Metalworking
- Packaging
- Buffing
- Screening
- Grinding
- Weighing
- Polishing
- Finishing
- Blending
- Sanding
- Filling
- Sawing
- Material Handling
- And more



Model VB-1500 (Bench)



Clean air. It's what we do.™

## IMPROVES WORKER PRODUCTIVITY AND REDUCES FACILITY MAINTENANCE

The V Series is available in three configurations: an integrated downdraft bench, a portable unit with swing arm and a free standing system. Installation is simple, requiring an electrical connection and a compressed air connection for the in-place cleaning option.

Most importantly, because the V Series removes dangerous contaminants that can cause respiratory problems, it helps your factory comply with OSHA regulations and significantly reduces lost work time. Plus, it prevents dusts from migrating to areas with sensitive electrical and mechanical equipment—reducing facility maintenance, too.



Wide variety of application-specific media.

## V Series *PULSE BLAST*

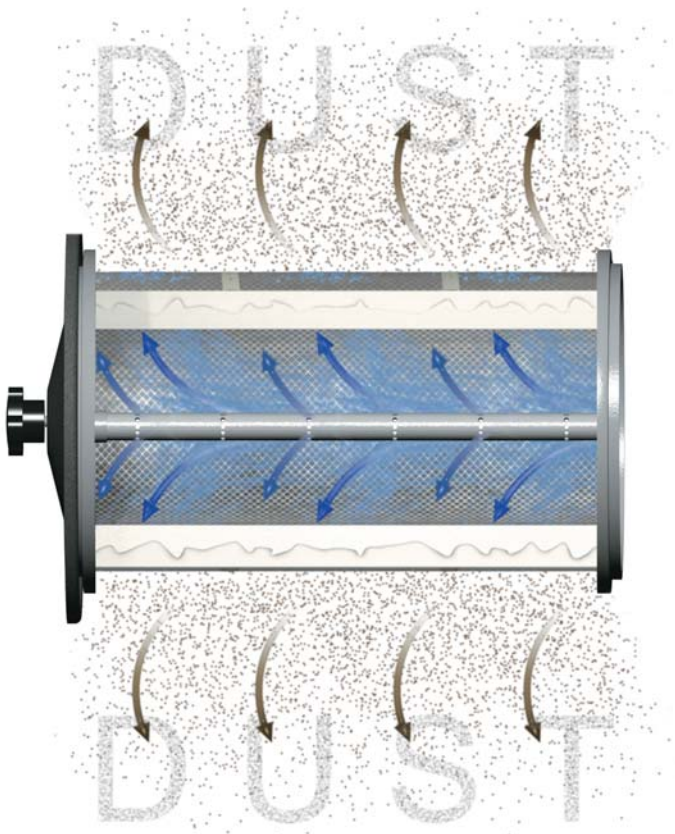

## STANDARD FEATURES

- Available with a wide selection of high-efficiency filters including fire retardant, wide pleat, washable, spun-bond polyester, PTFE and more.
- Auto-cleaning function automatically cleans filter after unit is shut off.
- Unique acoustic sound attenuation ensures quiet operation below 82 dBA.
- Assembled system is ready for use.
- Fast, tool-free filter change-out for easy inspection and maintenance.
- Powder coated finish on all components prevents fading and chalking.
- Large-capacity dust drawer offers easy dust removal and disposal.
- Pressure gauge indicates when filter requires replacement.

## DOWNDRAFT BENCH

### MODELS VB-750 AND VB-1500

The V Series downdraft bench is specifically designed for applications where workers need an integrated collection area and work surface that also draws contaminants away from the worker's breathing zone. Model VB is ideal for grinding and finishing operations of small parts and components.

### KEY OPTIONS

- Scratch-resistant and metallic grill work surfaces
- 5" casters for increased mobility
- HEPA filter
- Carbon after-filter
- Stainless-steel construction

Heavy-duty work surface supports up to 75 lb/sq ft.

Ergonomically designed for operator comfort.

Side wings and back panels can be easily removed to accommodate larger work pieces.

Even air distribution provides effective dust control over the entire work surface.



VB-1500

Dust drawer release for easy removal.



VB-750



Panels can be easily removed for large parts.



Clean air. It's what we do.™

## SELF-CONTAINED SYSTEM

### MODELS VF-750 AND VF-1500

Serving as the airflow and filtration source for an entire system, this self-contained system is the perfect choice for economical and efficient dust collection. Ideal for ducted operation, the VF system's small cabinet makes it easy to position close to the dust source—saving valuable floor space.

### KEY OPTIONS

- 5" casters for increased mobility
- HEPA filters
- Carbon after-filters
- Stainless-steel construction

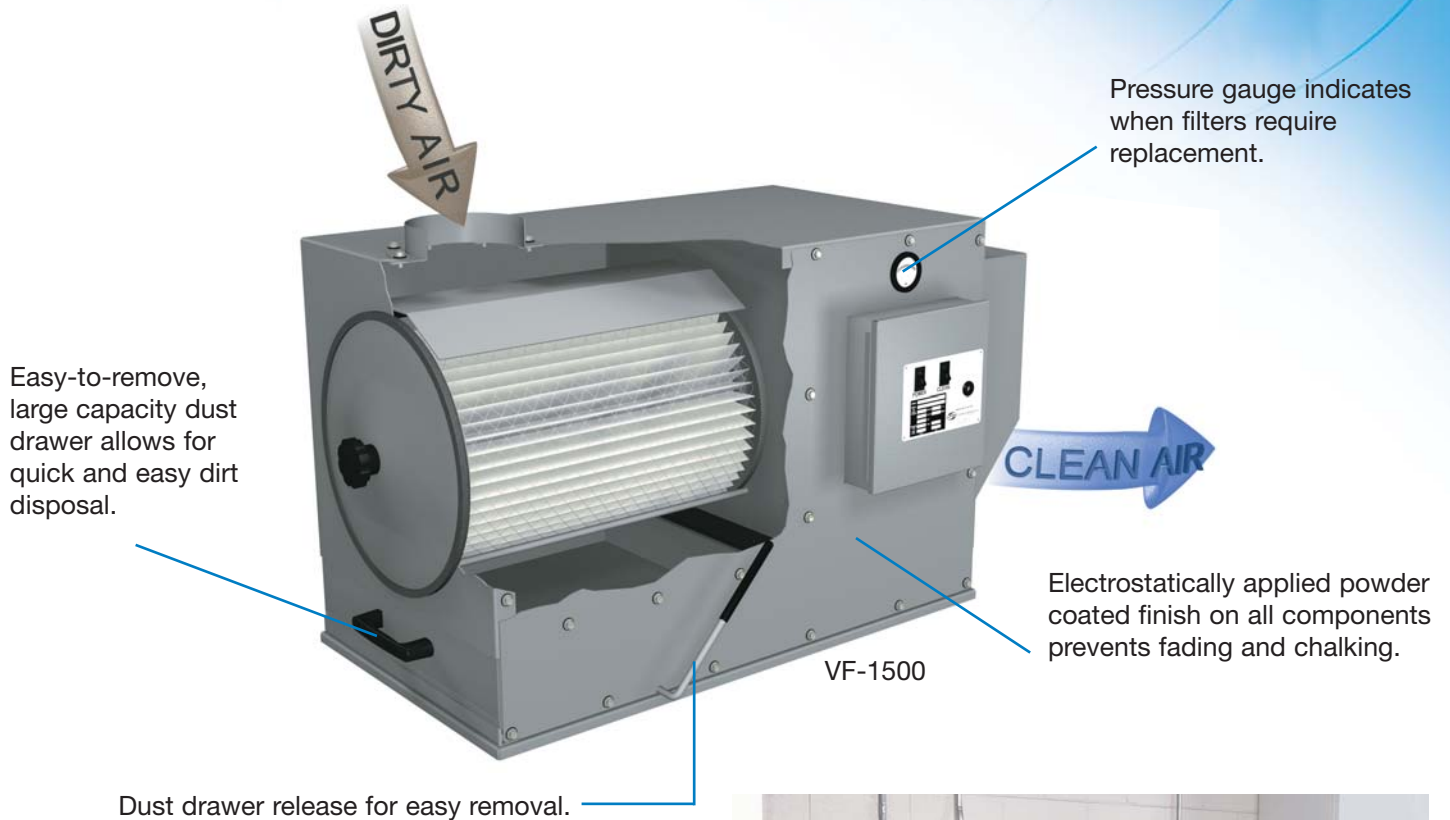

## PORTABLE SYSTEM

### MODELS VP-750 AND VP-1500

The V Series portable dust collector is ideal for applications where large pick-up hoods are impractical, where dust and smoke-producing machinery is used intermittently and where employees move from one work station to another. By positioning the swing arm and hood directly over the smoke or dust, Model VP removes harmful contaminants before they enter a worker's breathing zone.

High-quality swing arm features unique hood design for superior fume collection.

Low-profile cabinet provides low center of gravity for easy maneuverability and arm positioning.

### KEY OPTIONS

- 7', 10' and 14' long industrial swing arms
- HEPA filter
- Carbon after-filter
- 5" casters for increased mobility
- Stainless-steel construction

Industrial grade 15' power cord maximizes system reach and positioning during operation.

Easy-access handle offers convenient factory portability.

Durable 5" casters provide excellent system mobility.

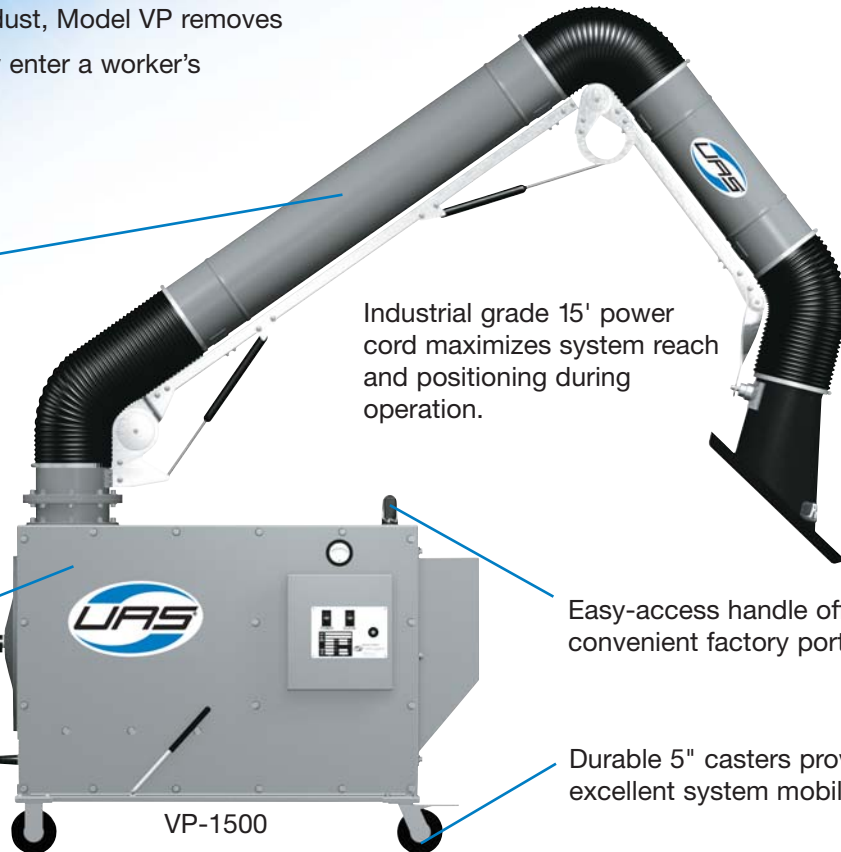

VP-1500



Fast, tool-free filter change-out.



Clean air. It's what we do.™

# SPECIFICATIONS

Model	Nominal Airflow (CFM)	Filter Area (ft <sup>2</sup> )	Sound* Level (dBA)	Motor** (HP)	SCF Per Pulse	Dimensions			Shipping Weight (lbs)
						Length (in.)	Width (in.)	Height (in.)	
VB-750	750	141	79	1.5/3.0	1.1	38-13/16	30-1/4	46-13/16	385
VB-1500	1500	283	77	1.5/3.0	1.3	52-3/4	30-1/4	46-13/16	485
VF-750	750	141	74	3.0	1.1	38-13/16	27-7/16	31-3/4	342
VF-1500	1500	283	81	3.0	1.3	52-3/4	27-7/16	31-3/4	425
VP-750	750	141	74	1.5/3.0	1.1	38-13/16	30	38-9/16	402
VP-1500	1500	283	81	3.0	1.3	52-3/4	30	38-9/16	502

\*Units tested in accordance with AMCA 300 at 5'.

\*\*Horsepower is dependant upon flow requirement and can vary within model size.

Motor HP	Power Supply	Amp Draw
1.5	115/1/60	16.4
1.5	230/1/60	8.2
1.5	208/3/60	4.9
1.5	230/3/60	4.6
1.5	460/3/60	2.3
1.5	575/3/60	1.8
3	208/3/60	8.1
3	230/3/60	7.6
3	460/3/60	3.8
3	575/3/60	3.0

## MODEL DIMENSIONS

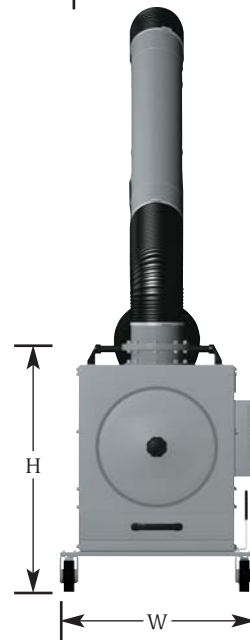
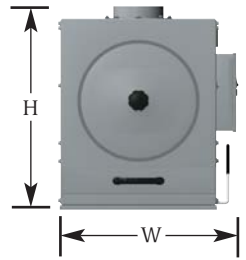
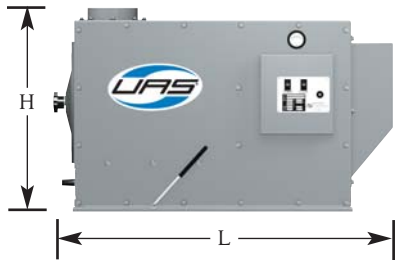
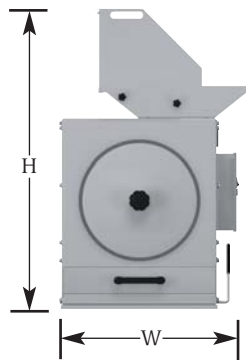
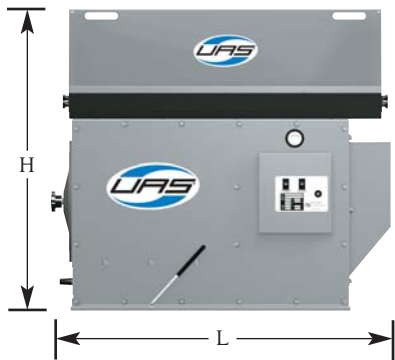

### MODEL VB

Practical bench provides an integrated collection area and work surface.

### MODEL VF

Small, ducted system for capturing dust at the source.

### MODEL VP

Portable unit used in applications where hoods are impractical.

## WHY CHOOSE UNITED AIR SPECIALISTS?

**A world-renowned reputation.** For more than 35 years, we've been the industry leader in air quality technology — a proven track record that speaks for itself.

**Commitment to quality products.** Measuring our quality against documented expectations, we practice continuous improvement methods to anticipate challenges and implement successful solutions.

**Unparalleled customer support.** As a customer-driven solutions provider, we earn credibility and establish successful relationships by exceeding expectations for professional service and attitude.

**Innovative technical leadership.** Always, we keep technology at the forefront — ensuring continuous product advancements through ongoing investments in design and manufacturing.

### UAS HEADQUARTERS – USA

4440 Creek Road  
Cincinnati, Ohio 45242  
1-800-252-4647  
www.uasinc.com

AN ISO9001 CERTIFIED COMPANY

### UAS – GERMANY

Otto-Hahn-Strasse 6  
D-65520 Bad Camberg  
Ph: +49-6434-94220  
E-mail: info@uas-inc.de

### UAS – UNITED KINGDOM

PO Box 17  
Folly Lane  
Warrington, Cheshire  
England WA5 0NP  
Ph: +44-1925-654321  
E-mail: post@clarcoruk.com

### UAS – ASIA

Flat 1, 15/F, Block 1  
Grand Pacific Views, Palatial Coast  
Siu Lam, Tuen Mun  
New Territories, Hong Kong  
Ph: +852-2814-7722  
E-mail: dlee@clarcor.com



*Clean air. It's what we do.™*